

ASSEMBLY INSTRUCTIONS FOR GRAVITY SWING

FRAME ASSEMBLY

Ref. No.	Description
1	Front Frame
2	Back Frame
3	Horizontal Frame Brace
4	Vertical Support Bar (2)
5	Bearing Bracket Assembly (2)
6	Frame Locking Strap (2)

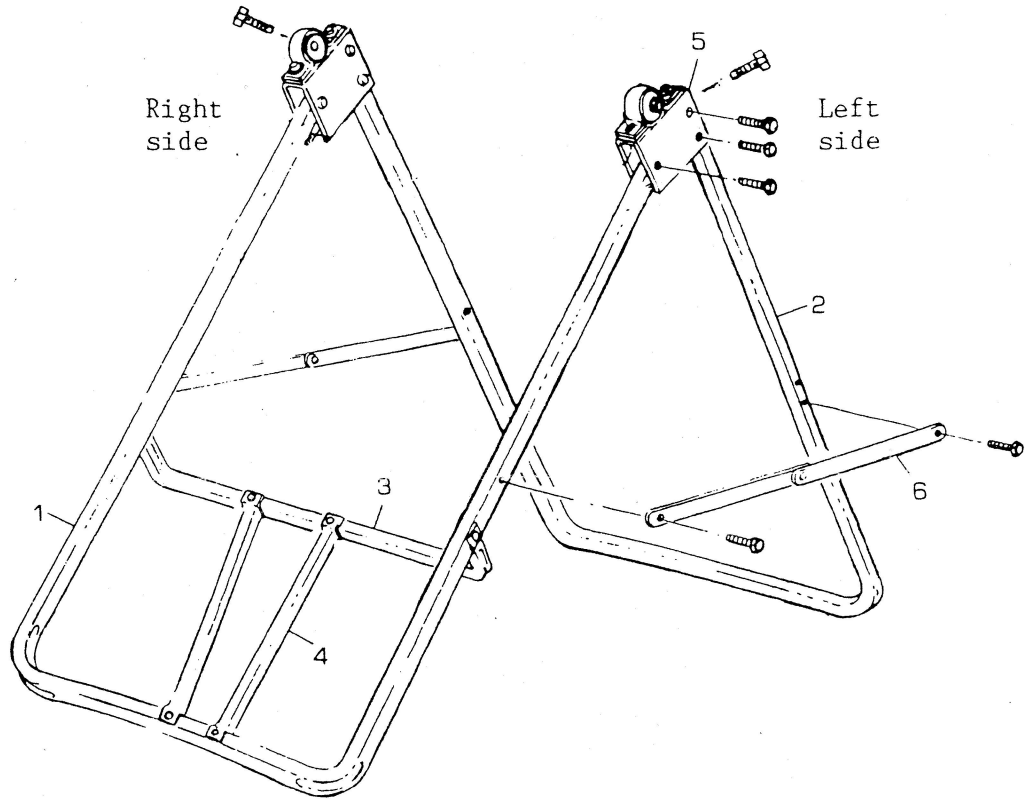

1. Bolt BEARING BRACKET ASSEMBLY on to each side of BACK FRAME, as shown (use 1½" bolts).
2. Bolt FRONT FRAME on to BEARING BRACKET ASSEMBLY in same manner.
3. Bolt FRAME LOCKING STRAPS to outer sides of FRAME (use 1¼" bolts).
4. Mount HORIZONTAL BRACE (use 1¼" bolts).
5. Bolt two VERTICAL SUPPORT BARS into place.
6. Insert ½" x 2" bolt through hole in each BEARING BRACKET ASSEMBLY. Secure with ½" nut on each side. Bolt should protrude on inner side of BEARING BRACKET ASSEMBLY.

BED ASSEMBLY

Ref. No.	Description
7	Bed
8	Pivot Arm R&L
9	Guide Clip
10	Guide Clip Bar

Note: 9 Guide Clip is identical to 13 Rear Ankle Clip.

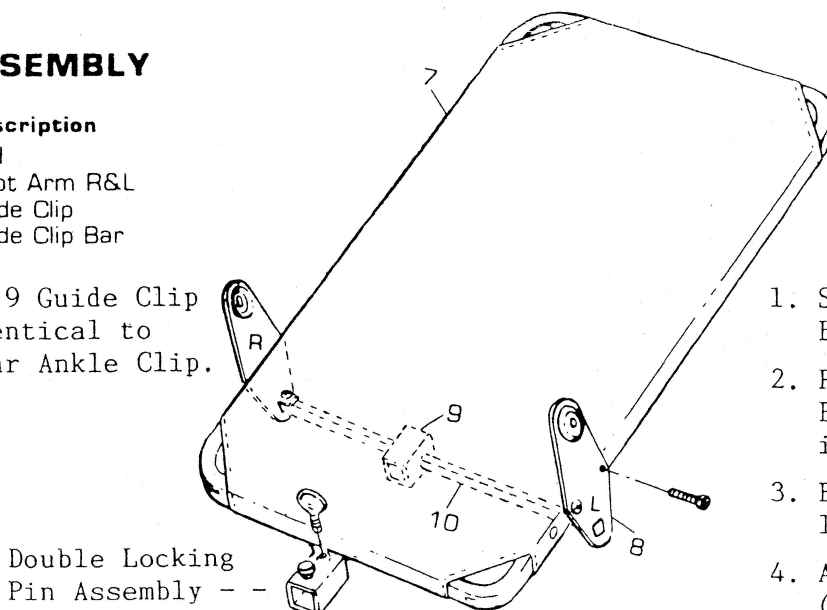

1. Slide GUIDE CLIP on to GUIDE CLIP BAR.
2. Place PIVOT ARM on to each end of BAR. (Extruded end of PIVOT ARM is at top and faces out).
3. Bolt BAR to PIVOT ARM tabs (use 1¼" bolts).
4. Attach entire assembly on to BED (use 1½" bolts). It is essential that PIVOT ARMS are properly placed, as shown.