

ASSEMBLY INSTRUCTIONS (Continued)

MOUNTING BED

Place PIVOT ARM-R on to protruding bolt on right BEARING BRACKET ASSY and PIVOT ARM-L on opposite bolt. Secure with lock washer and 1/2" nut.

Note: It is essential that PIVOT ARMS are properly mounted. Be sure R&L ARMS are mounted as shown.

HEIGHT ADJUSTING RAIL

Ref. No.	Description
11	Height Adjusting Rail
12	Locking Clip
13	Rear Ankle Clip
14	Rear Ankle Bar
15	Rubber Ankle Support (4)
16	Bottom Bracket Assembly
17	Footbar
18	Locking Handle
19	Front Ankle Bar
20	Safety Strap (not shown)
	Plastic Caps (not shown)

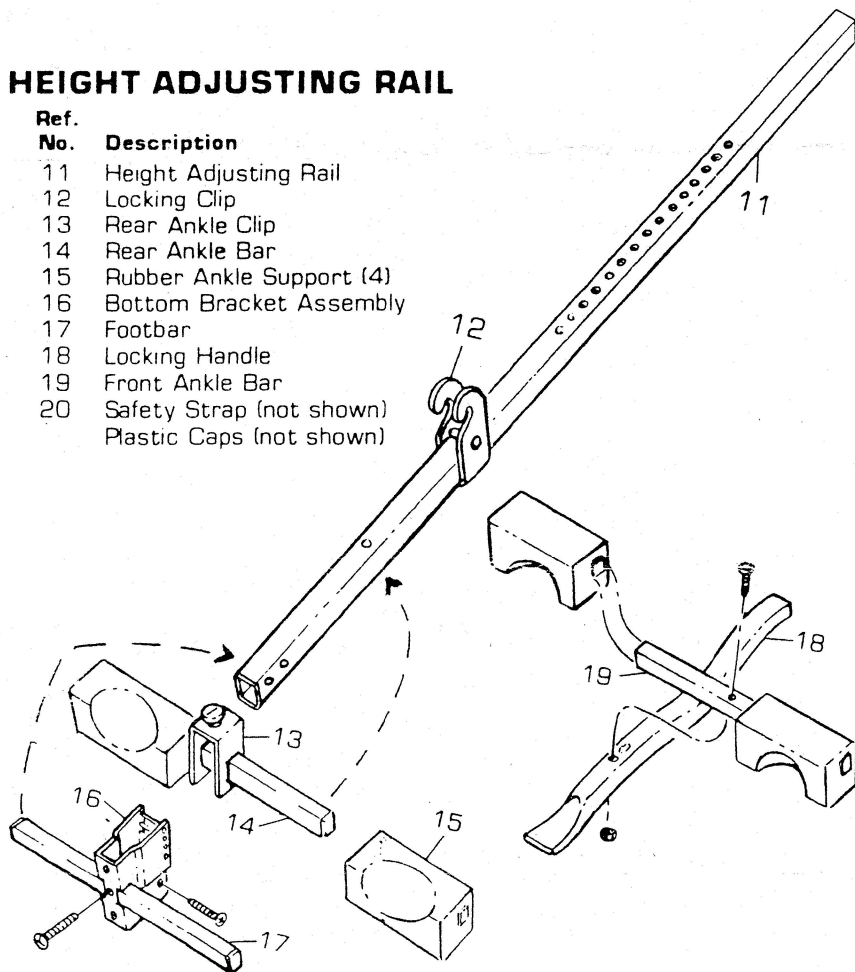

1. Bolt LOCKING CLIP on to RAIL (use 1 1/2" bolt). Bolt 1" spacer into place.
2. Slide REAR ANKLE BAR through REAR ANKLE CLIP. Slide RUBBER ANKLE SUPPORT on to each side of BAR. Slide entire assembly on to RAIL, and bolt into place (use 2 1/4" bolt).
3. Slide FOOTBAR through BOTTOM BRACKET ASSEMBLY. Bolt into place (use 1 1/4" bolt). Bolt entire assembly on to RAIL (use 1 1/2" bolt).
4. Insert assembled HEIGHT ADJUSTING RAIL through DOUBLE LOCKING PIN ASSEMBLY and continue through GUIDE CLIP. must go through GUIDE CLIP.
1. Bolt FRONT ANKLE BAR on to LOCKING HANDLE (use 2" stainless steel bolt). Slide RUBBER ANKLE SUPPORTS on to each side of BAR.

1. Attach SAFETY STRAP by placing hook in each hole in BACK FRAME just above FRAME LOCKING STRAP.

NOTE:

To fold Gravity Swing, slide Height Adjusting Rail up as far as possible and secure with Double Locking Pin Assembly. Swing Bed forward and rotate to rest against Vertical Support Bars. Pull Frame Locking Straps up to desired position.

ANTI-GRAVITY SWING INC

14250 ROMINE CARLETON MICHIGAN 48117

1-888-292-1053~ 1-800-666-4741~ 1-734-654-2233